

Fluid Cooling Industrial AOC Series

Performance Notes

- AC motors
- Core filter
- 3/4" tubes
- Low cost
- Industrial duty
- Quiet operation
- For low flow rates
- Oil flows to 150 GPM
- Perfect for off-line recirculation loop
- Mounting brackets included
- SAE connections
- Single or three-phase 60/50 HZ motors
- Filter standard (not available on AOC-08)



OPTIONS
 NPT or BSPP oil connections
 Serviceable internal pressure bypass (not available on AOC-08)

Ratings

Maximum Operating Pressure
 300 PSI

Test Pressure
 300 PSI

Maximum Operating Temperature
 350°F

Materials

- Tubes** Copper
- Fins** Aluminum
- Turbulators** Aluminum
- Fan Blade** Aluminum with steel hub
- Fan Guard** Steel with black baked enamel finish
- Cabinet** Steel with powder coat finish
- Manifolds** Copper: Model AOC-08
 Steel: Models AOC-19 – AOC-70
- Connections** Brass: Model AOC-08
 Steel: Models AOC-19 – AOC-70
- Nameplate** Aluminum
- Filter** Stainless frame with washable media

Internal Pressure Bypass Options

AOC-08
 Available in one pass (30 and 60 PSI), two pass (60 PSI), designs only. Valves are built into tubes and do not affect external dimensions. All steel valves. Non-serviceable.

AOC-19 through AOC-33
 Available in 30 PSI or 60 PSI settings. 3/4", external, all steel valve. May be removed for servicing.

AOC-37 through AOC-70
 Available in 30 PSI or 60 PSI settings. 1 1/2", external, all steel valve. May be removed for servicing.

How to Order (AOC-08 models only)

AOC	-	0 8	-		-		-	
Model Series		Model Size Selected		Number of Passes		Connection Type		Bypass*
AOC - Standard				1 - One Pass 2 - Two Pass 4 - Four Pass		1 - NPT 2 - SAE 3 - BSPP		Blank - No Bypass 30 - 30 PSI 60 - 60 PSI
								Specify Motor Required
								115/230V Single Phase No Motor

*Bypass valve not available in Four Pass. 60 PSI only on Two Pass
 This is a partial flow pressure bypass only. It is not designed to be a full flow system bypass.

How to Order (Models AOC-19 through AOC-70)

AOC	-		-		-		-	
Model Series		Model Size Selected		Connection Type		Bypass*		Specify Motor Required
AOC - Standard				1 - NPT 2 - SAE 3 - BSPP		Blank - No Bypass 30 - 30 PSI 60 - 60 PSI		115/230V Single Phase 208-230/460V Three Phase 575 Volt No Motor

*Available on One Pass only
 This is a partial flow pressure bypass only. It is not designed to be a full flow system bypass.

Dimensions

Models AOC-19 through AOC-33

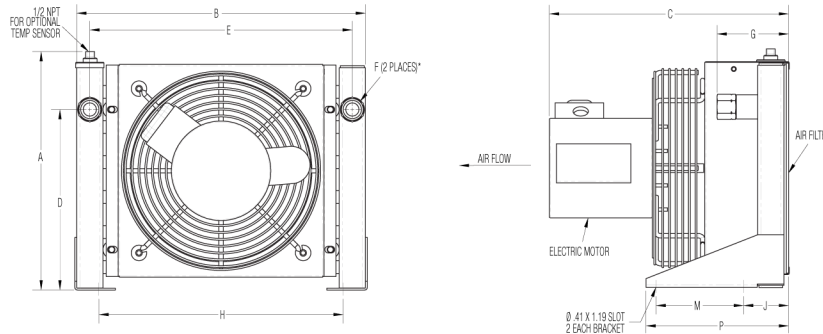

Models AOC-37 through AOC-70

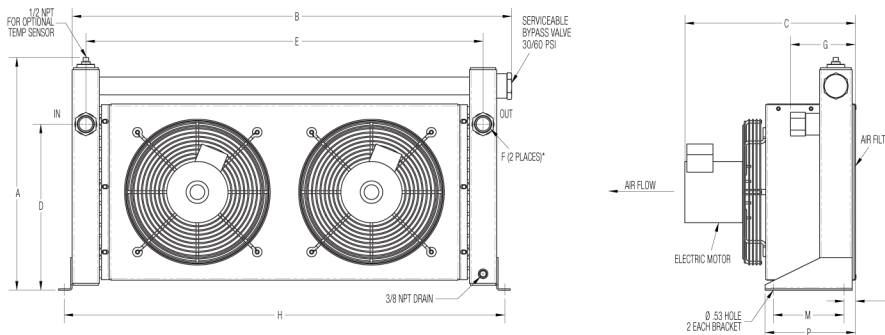

Model	A		B		C	D	E	F		G		H	J	M	P	Weight LBS	60 HZ CFM
	No Bypass	Bypass	No Bypass	Bypass				SAE	NPT & BSPP	SAE	NPT & BSPP						
AOC-19	13.62	16.00	16.50	18.16	13.08	10.31	15.00	#12	.75	3.05	4.12	13.96	2.61	5.00	8.18	19	750
AOC-22	15.62	18.00	22.00	23.66	12.19	12.31	20.50	#12	.75	3.05	4.12	19.46	2.61	5.00	8.18	33	1150
AOC-24	19.62	22.00	24.75	26.41	13.19	16.31	23.25	#12	.75	3.05	4.12	22.21	2.61	5.00	8.18	46	1900
AOC-33	25.62	28.00	30.25	31.91	13.19	22.31	28.78	#16	1.00	3.05	4.34	27.71	2.61	5.00	8.18	65	2150
AOC-37	18.50	21.38	39.00	40.38	15.66	15.25	36.50	#20	1.25	4.62	5.97	40.50	1.06	6.50	8.31	95	2150
AOC-50	22.50	25.38	41.00	42.38	15.62	19.25	38.50	#20	1.25	4.68	6.03	42.50	1.12	6.50	8.37	120	3200
AOC-54	30.50	33.28	42.00	43.38	17.09	27.25	39.50	#24	1.50	4.89	6.30	43.76	1.87	9.00	12.37	154	3800
AOC-57	36.50	39.38	48.00	49.38	16.72	32.75	45.50	#32	2.00	6.68	8.15	49.76	1.87	9.00	12.37	190	4200
AOC-70	38.38	41.25	51.00	52.38	22.62	34.00	48.50	#32	2.00	8.44	9.91	52.75	1.62	9.00	12.12	322	7500

NOTE: All dimensions in inches. We reserve the right to make reasonable design changes without notice. Inlet and outlet oil ports reversible if bypass valve option is not used.

Specifications

Electric Motor Data

Model	Motor HP	No. of Motors	Frame Size	Single Phase	Three Phase	575 Volt	RPM	Type	Bearings B-Ball	Thermal Overload	dB(A) 3 FT
AOC-19	1/4	1	Custom	115/230V/60/50 HZ 4.2/2.1 Amps Full Load 60 HZ 2.8/1.4 Amps Full Load 50 HZ	208-230/460V/60 HZ 190/380-415V/50 HZ 1.0/0.5 Amps Full Load	575/500V/60/50 HZ .65 Amps Full Load 60 HZ .60 Amps Full Load 50 HZ	1700 (60 HZ) 1350 (50 HZ)	TEAO	B	Yes	80
AOC-22	1/4	1	Custom					TEAO	B	Yes	80
AOC-24	1/4	1	Custom					TEAO	B	Yes	80
AOC-33	1/4	1	Custom					TEAO	B	Yes	80
AOC-37	1/4	2	Custom					TEAO	B	Yes	84
AOC-50	1/4	2	Custom					TEAO	B	Yes	84
AOC-54	1/4	2	Custom					TEAO	B	Yes	84
AOC-57	1/4	2	Custom					TEAO	B	Yes	84
AOC-70	1	2	56C	115/208-230V/60 HZ 12.8/6.4 Amps Full Load	208-230/460V/60 HZ 190/380-415V/50 HZ 3.4/1.7 Amps Full Load 60 HZ 3.6/1.9 Amps Full Load 50 HZ	575/500V/60/50 HZ 1.5 Amps Full Load 60 HZ 1.4 Amps Full Load 50 HZ	1725 (60 HZ) 1425 (50 HZ)	TEFC	B	No	90

NOTE: Amp ratings are per motor. Motors are CSA approved/marked.

Selection Procedure

Performance Curves are based on 50SSU oil leaving the cooler 40°F higher than the ambient air temperature used for cooling. This is also referred to as a 40°F approach temperature.

STEP 1 Determine the Heat Load. This will vary with different systems, but typically coolers are sized to remove 25 to 50% of the input nameplate horsepower.

(Example: 100 HP Power Unit x .33 = 33 HP Heat load.)

If BTU/HR is known: $HP = \frac{BTU/HR}{2545}$

STEP 2 Determine Approach Temperature. Desired oil leaving cooler °F – Ambient air temp. °F = Actual Approach

STEP 3 Determine Curve Horsepower Heat Load. Enter the information from above:

Horsepower heat load x $\frac{40 \times C_v}{\text{Actual Approach}}$ = Curve Horsepower

STEP 4 Enter curves at oil flow through cooler and curve horsepower. Any curve above the intersecting point will work.

STEP 5 Determine Oil Pressure Drop from Curves:
 ● = 5 PSI ■ = 10 PSI ▲ = 20 PSI + = 40 PSI Multiply pressure drop from curve by correction factor found in oil Δ P correction curve.

Desired Reservoir Temperature

Return Line Cooling: Desired temperature is the oil temperature leaving the cooler. This will be the same temperature that will be found in the reservoir.

Off-Line Recirculation Cooling Loop: Desired temperature is the oil temperature entering the cooler. In this case, the oil temperature change must be determined so that the actual oil leaving temperature can be found. Calculate the oil temperature change (oil Δ T) with this formula:
 Oil Δ T = (BTU's/HR) / (GPM Oil Flow x 210).

To calculate the oil leaving temperature from the cooler, use this formula:
 Oil Leaving Temp. = Oil Entering Temp – Oil Δ T.

This formula may also be used in any application where the only temperature available is the entering oil temperature.

Oil Pressure Drop: Most systems can tolerate a pressure drop through the heat exchanger of 20 to 30 PSI. Excessive pressure drop should be avoided. Care should be taken to limit pressure drop to 5 PSI or less for case drain applications where high back pressure may damage the pump shaft seals.

Oil Temperature

Typical operating temperature ranges are:

Hydraulic Motor Oil	110° - 130°F
Hydrostatic Drive Oil	130° - 180°F
Bearing Lube Oil	120° - 160°F
Lube Oil Circuits	110° - 130°F

Performance Curves

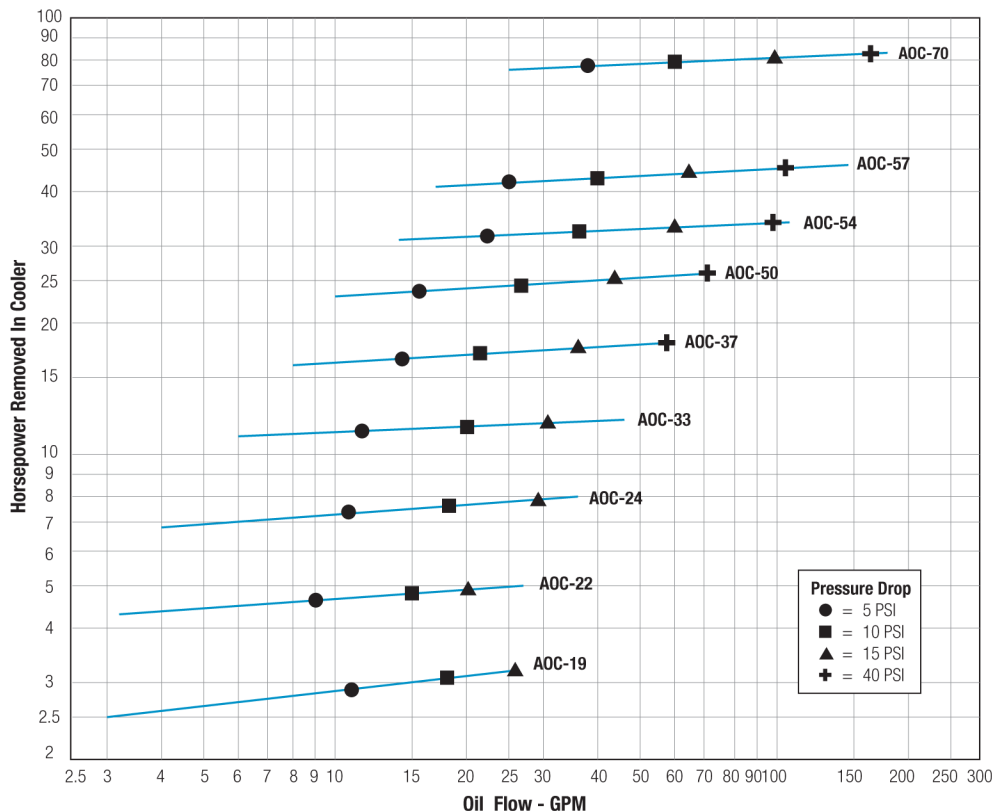

Oil Pressure Correction

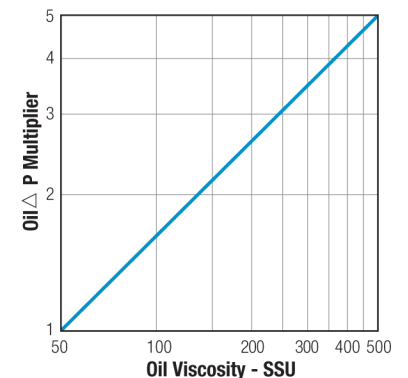

De-rate cooler performance by 10% when used in 50 HZ service.

C_v Viscosity Correction

Average Oil Temp °F	OIL				
	SAE 5 110 SSU at 100°F 40 SSU at 210°F	SAE 10 150 SSU at 100°F 43 SSU at 210°F	SAE 20 275 SSU at 100°F 50 SSU at 210°F	SAE 30 500 SSU at 100°F 65 SSU at 210°F	SAE 40 750 SSU at 100°F 75 SSU at 210°F
100	1.14	1.22	1.35	1.58	1.77
150	1.01	1.05	1.11	1.21	1.31
200	.99	1.00	1.01	1.08	1.10
250	.95	.98	.99	1.00	1.00

AOC-08 Model Only

One Pass

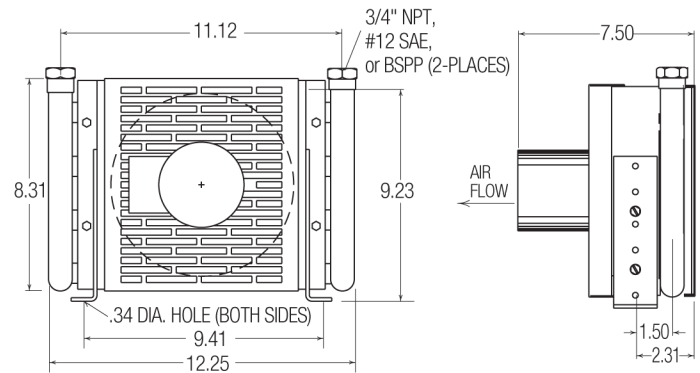
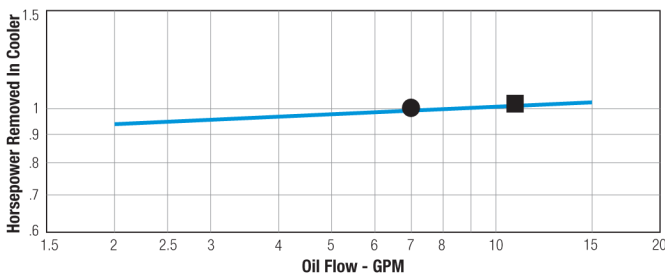

Two Pass

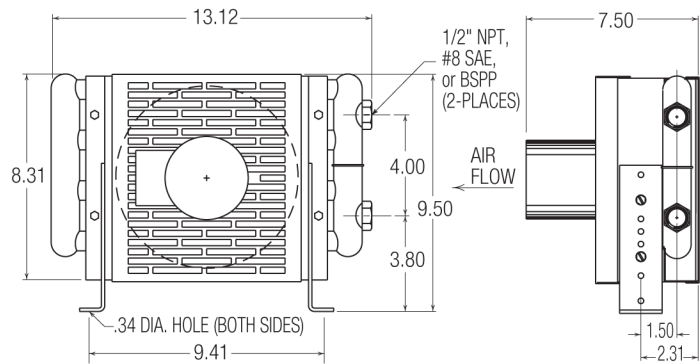
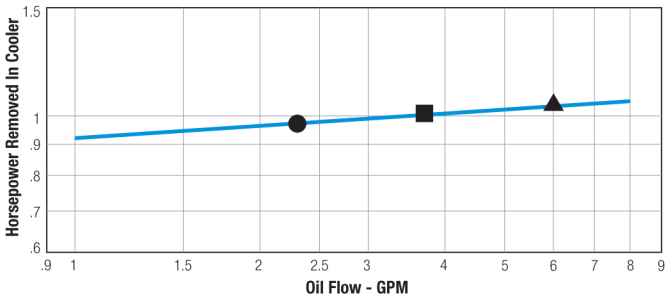

Four Pass

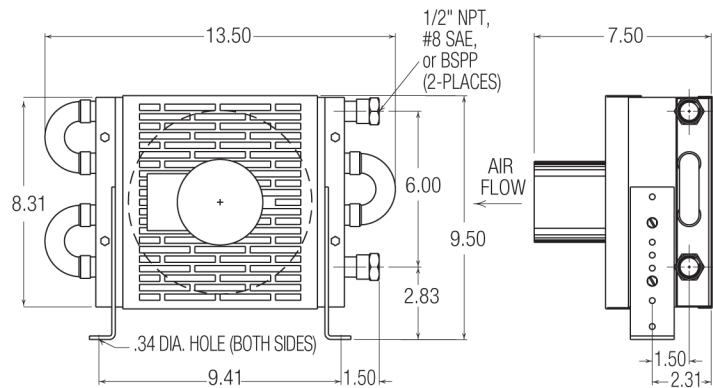
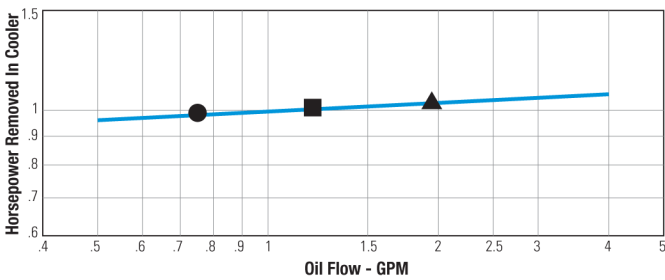

Specifications

Electric Motor Data

Model	Motor Power	115/230 V	50/60 HZ	Type	RPM	Bearings S-Sleeve	Thermal Overload	Shipping Weight LBS	dB(A) 3 FT	CFM 260 HZ
AOC-08	1/30	115 V 230 V	1.1 Amps Full Load .7 Amps Full Load	TEAO	3000	S	Yes	12	70	208