

Fluid Cooling Shell & Tube B / SB Series

0916

Performance Notes

- Young Touchstone thermal interchange
- Competitively priced
- 1/4" or 3/8" tubes available
- Water to water applications
- Sea water applications
- NPT, SAE O-Ring, SAE flange, or BSPP shell side connections available
- End bonnets removable for servicing
- Mounting feet included (may be rotated in 90° increments)



Options
90/10 copper nickel cooling tubes, bronze end bonnets for sea water service and zinc anodes

Ratings

Maximum Operating Pressure - Shell Side
250 PSI

Maximum Operating Pressure - Tube Side
150 PSI

Maximum Operating Temperature
350°F

Materials

Tubes Copper
Hubs & Tubesheets Steel or brass
Shell Steel or brass
Baffles Brass
End Bonnets Cast iron
Mounting Brackets Steel
Gaskets Nitrile rubber/cellulose fiber
Nameplate Aluminum foil

How to Order

<input type="text"/>	-	<input type="text"/>	-	<input type="text"/>	-	<input type="text"/>	-	<input type="text"/>	-	<input type="text"/>	-	<input type="text"/>	-	<input type="text"/>		
Model Series		Model Size Selected		Baffle Spacing		Tube Diameter Code		Tubeside Passes		Shell Material		Cooling Tube Material		End Bonnet Material		Zinc Anodes
SB SBF B BS BM BF BFM				A - 1.125 B - 2.25 C - 4.5 D - 9.0		4 - 1/4" 6 - 3/8"		O - One Pass T - Two Pass F - Four Pass		Blank - Steel BR - Brass		Blank - Copper CN - CuNi		Blank - Cast Iron B - Bronze		Blank - None Z - Zinc

ADD FOR B SERIES MODELS ONLY:
BR-CN-B-Z is to be used for all seawater/dirty water applications.

Steel Hub

SB = NPT Shell Side, NPT Tube Side
SBF = SAE Flange (with UNC threads) Shell Side connections; NPT Tube Side connections

Brass Hub

B = NPT Shell Side connections; NPT Tube Side connections
BS = SAE O-Ring Shell Side connections; NPT Tube Side connections
BM = BSPP Shell Side connections; BSPP Tube Side connections
BF = SAE Flange (with UNC threads) Shell Side connections; NPT Tube Side connections
BFM = SAE Flange (with Metric threads) Shell Side connections; BSPP Tube Side connections

SAE flanges available on some models. Consult factory for details.

Dimensions

One Pass

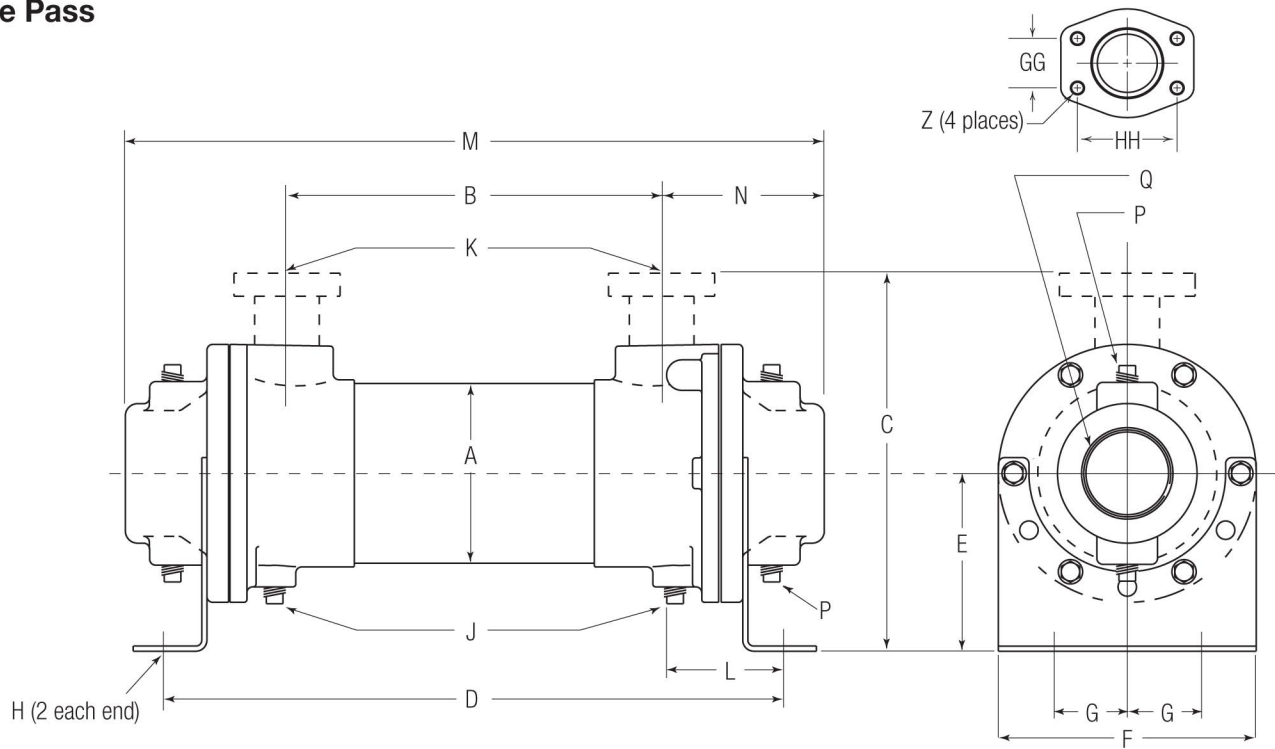

Flange Size	GG	HH	Z - CF	Z - CFM
1	1.03	2.06	3/8-16 UNC	M-10
1.50	1.41	2.75	1/2-13 UNC	M-12
2	1.69	3.06	1/2-13 UNC	M-12
3	2.44	4.19	5/8-11 UNC	M-16

Model	A	B	C		D	E	F	G	H	J NPT	K		L	M	N	P NPT	Q NPT
			NPT/BSPP SAE O-Ring	SAE Flange							NPT/BSPP Flange	SAE O-Ring					
B-401	2.125	7.62	3.50	—	11.01	1.94	2.62	.88	.41 Dia.	—	*.50	#8, 3/4-16 UNF-2B	1.72	11.24	1.81	—	1.00
B-402	2.125	16.62	3.50	—	20.01	1.94	2.62	.88	.41 Dia.	—	*.50	#8, 3/4-16 UNF-2B	1.72	20.24	1.81	—	1.00
B-701	3.656	7.00	6.25	C/F	12.01	3.62	5.25	1.50	.44 x 1.00	(2) .38	1.00	#16	2.69	13.64	3.24	(4) .38	1.50
B-702	3.656	16.00	6.25	C/F	21.01	3.62	5.25	1.50	.44 x 1.00	(2) .38	1.00	1 1/16-12 UNF-2B	2.69	22.64	3.24	(4) .38	1.50
B-703	3.656	25.00	6.25	C/F	30.01	3.62	5.25	1.50	.44 x 1.00	(2) .38	1.00	1 1/16-12 UNF-2B	2.69	31.64	3.24	(4) .38	1.50
B-1002	5.125	15.50	7.38	8.46	21.71	4.00	6.75	2.00	.44 x 1.00	(6) .38	1.50	#24	3.06	23.60	4.05	(4) .38	2.00
B-1003	5.125	24.50	7.38	8.46	30.71	4.00	6.75	2.00	.44 x 1.00	(6) .38	1.50	1 1/8-12 UN-2B	3.06	32.60	4.05	(4) .38	2.00
B-1004	5.125	33.50	7.38	8.46	39.71	4.00	6.75	2.00	.44 x 1.00	(6) .38	1.50	1 1/8-12 UN-2B	3.06	41.60	4.05	(4) .38	2.00
B-1202	6.125	14.62	8.81	10.50	21.50	4.75	7.50	2.50	.44 x .88	(6) .38	2.00	#32 2 1/2-12 UN-2B	3.44	24.38	4.88	(4) .50	3.00
B-1203	6.125	23.50	8.81	10.50	30.38	4.75	7.50	2.50	.44 x .88	(6) .38	2.00		3.44	33.25	4.88	(4) .50	3.00
B-1204	6.125	32.38	8.81	10.50	39.25	4.75	7.50	2.50	.44 x .88	(6) .38	2.00		3.44	42.12	4.88	(4) .50	3.00
B-1205	6.125	41.38	8.81	10.50	48.25	4.75	7.50	2.50	.44 x .88	(6) .38	2.00		3.44	51.12	4.88	(4) .50	3.00
B-1206	6.125	50.50	8.81	10.50	57.38	4.75	7.50	2.50	.44 x .88	(6) .38	2.00		3.44	60.25	4.88	(4) .50	3.00
B-1207	6.125	59.50	8.81	10.50	66.38	4.75	7.50	2.50	.44 x .88	(6) .38	2.00		3.44	69.25	4.88	(4) .50	3.00
B-1208	6.125	38.38	8.81	10.50	75.25	4.75	7.50	2.50	.44 x .88	(6) .38	2.00		3.44	78.12	4.88	(4) .50	3.00
B-1602	8.00	13.60	12.13	15.61	22.38	6.50	8.62	3.50	.44 x 1.00	(6) .38	3.00	—	4.39	26.62	6.52	(4) .50	4.00
B-1603	8.00	22.60	12.13	15.61	31.38	6.50	8.62	3.50	.44 x 1.00	(6) .38	3.00	—	4.39	35.62	6.52	(4) .50	4.00
B-1604	8.00	31.60	12.13	15.61	40.38	6.50	8.62	3.50	.44 x 1.00	(6) .38	3.00	—	4.39	44.62	6.52	(4) .50	4.00
B-1605	8.00	40.60	12.13	15.61	49.38	6.50	8.62	3.50	.44 x 1.00	(6) .38	3.00	—	4.39	53.62	6.52	(4) .50	4.00
B-1606	8.00	49.60	12.13	15.61	58.38	6.50	8.62	3.50	.44 x 1.00	(6) .38	3.00	—	4.39	62.62	6.52	(4) .50	4.00
B-1607	8.00	58.60	12.13	15.61	67.38	6.50	8.62	3.50	.44 x 1.00	(6) .38	3.00	—	4.39	71.62	6.52	(4) .50	4.00
B-1608	8.00	67.60	12.13	15.61	76.38	6.50	8.62	3.50	.44 x 1.00	(6) .38	3.00	—	4.39	80.62	6.52	(4) .50	4.00
B-1609	8.00	76.60	12.13	15.61	85.38	6.50	8.62	3.50	.44 x 1.00	(6) .38	3.00	—	4.39	89.62	6.52	(4) .50	4.00
B-1610	8.00	85.60	12.13	15.61	94.38	6.50	8.62	3.50	.44 x 1.00	(6) .38	3.00	—	4.39	98.62	6.52	(4) .50	4.00

*B-401 and B-402 SAE Flange not available. NOTE: We reserve the right to make reasonable design changes without notice. Consult factory. All dimensions are inches.

Dimensions

Two Pass

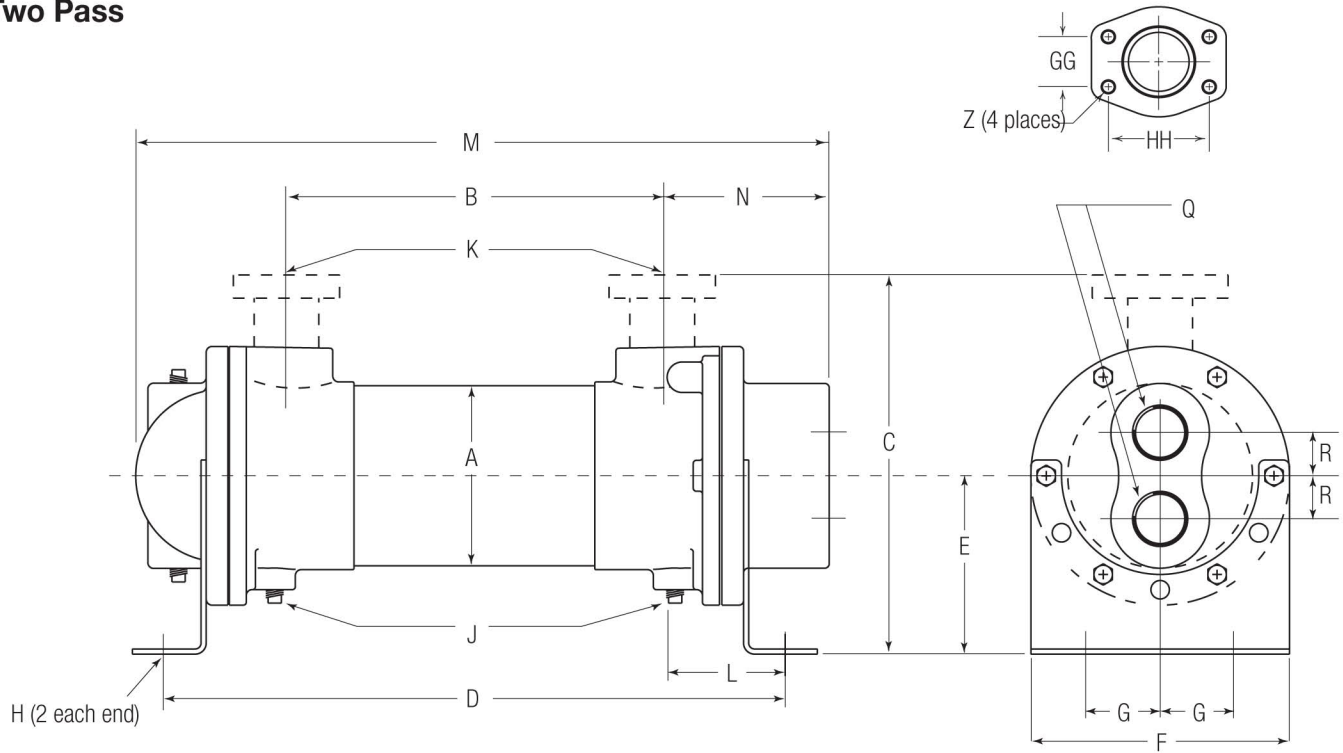

Flange Size	GG	HH	Z - CF	Z - CFM
1	1.03	2.06	3/8-16 UNC	M-10
1.50	1.41	2.75	1/2-13 UNC	M-12
2	1.69	3.06	1/2-13 UNC	M-12
3	2.44	4.19	5/8-11 UNC	M-16

Model	A	B	C		D	E	F	G	H	J NPT	K		L	M	N	P NPT	Q NPT	R	
			NPT/BSPP SAE O-Ring	SAE Flange							NPT/BSPP Flange	SAE O-Ring							
B-701	3.656	7.00	6.25	C/F	12.01	3.62	5.25	1.50	.44 x 1.00	(2) .38	1.00	#16	2.69	13.28	3.30	(2) .38	1.00	.88	
B-702	3.656	16.00	6.25	C/F	21.01	3.62	5.25	1.50	.44 x 1.00	(2) .38	1.00	1 1/16-12 UNF-2B	2.69	22.28	3.30	(2) .38	1.00	.88	
B-703	3.656	25.00	6.25	C/F	30.01	3.62	5.25	1.50	.44 x 1.00	(2) .38	1.00	UNF-2B	2.69	31.28	3.30	(2) .38	1.00	.88	
B-1002	5.125	15.50	7.38	8.46	21.71	4.00	6.75	2.00	.44 x 1.00	(6) .38	1.50	#24	3.06	23.29	3.80	(2) .38	1.50	1.19	
B-1003	5.125	24.50	7.38	8.46	30.71	4.00	6.75	2.00	.44 x 1.00	(6) .38	1.50	1 1/8-12 UN-2B	3.06	32.29	3.80	(2) .38	1.50	1.19	
B-1004	5.125	33.50	7.38	8.46	39.71	4.00	6.75	2.00	.44 x 1.00	(6) .38	1.50	UN-2B	3.06	41.29	3.80	(2) .38	1.50	1.19	
B-1202	6.125	14.62	8.81	10.50	21.50	4.75	7.50	2.50	.44 x .88	(6) .38	2.00	#32 2 1/2-12 UN-2B	3.44	23.94	4.56	(2) .50	2.00	1.44	
B-1203	6.125	23.50	8.81	10.50	30.38	4.75	7.50	2.50	.44 x .88	(6) .38	2.00		3.44	32.81	4.56	(2) .50	2.00	1.44	
B-1204	6.125	32.38	8.81	10.50	39.25	4.75	7.50	2.50	.44 x .88	(6) .38	2.00		3.44	41.69	4.56	(2) .50	2.00	1.44	
B-1205	6.125	41.38	8.81	10.50	48.25	4.75	7.50	2.50	.44 x .88	(6) .38	2.00		3.44	50.69	4.56	(2) .50	2.00	1.44	
B-1206	6.125	50.50	8.81	10.50	57.38	4.75	7.50	2.50	.44 x .88	(6) .38	2.00		3.44	59.81	4.56	(2) .50	2.00	1.44	
B-1207	6.125	59.50	8.81	10.50	66.38	4.75	7.50	2.50	.44 x .88	(6) .38	2.00		3.44	68.81	4.56	(2) .50	2.00	1.44	
B-1208	6.125	38.38	8.81	10.50	75.25	4.75	7.50	2.50	.44 x .88	(6) .38	2.00		3.44	77.69	4.56	(2) .50	2.00	1.44	
B-1602	8.00	13.60	12.13	15.61	22.38	6.50	8.62	3.50	.44 x 1.00	(6) .38	3.00		—	4.39	25.10	6.08	(2) .50	2.50	1.88
B-1603	8.00	22.60	12.13	15.61	31.38	6.50	8.62	3.50	.44 x 1.00	(6) .38	3.00		—	4.39	34.10	6.08	(2) .50	2.50	1.88
B-1604	8.00	31.60	12.13	15.61	40.38	6.50	8.62	3.50	.44 x 1.00	(6) .38	3.00		—	4.39	43.10	6.08	(2) .50	2.50	1.88
B-1605	8.00	40.60	12.13	15.61	49.38	6.50	8.62	3.50	.44 x 1.00	(6) .38	3.00	—	4.39	52.10	6.08	(2) .50	2.50	1.88	
B-1606	8.00	49.60	12.13	15.61	58.38	6.50	8.62	3.50	.44 x 1.00	(6) .38	3.00	—	4.39	61.10	6.08	(2) .50	2.50	1.88	
B-1607	8.00	58.60	12.13	15.61	67.38	6.50	8.62	3.50	.44 x 1.00	(6) .38	3.00	—	4.39	70.10	6.08	(2) .50	2.50	1.88	
B-1608	8.00	67.60	12.13	15.61	76.38	6.50	8.62	3.50	.44 x 1.00	(6) .38	3.00	—	4.39	79.10	6.08	(2) .50	2.50	1.88	
B-1609	8.00	76.60	12.13	15.61	85.38	6.50	8.62	3.50	.44 x 1.00	(6) .38	3.00	—	4.39	88.10	6.08	(2) .50	2.05	1.88	
B-1610	8.00	85.60	12.13	15.61	94.38	6.50	8.62	3.50	.44 x 1.00	(6) .38	3.00	—	4.39	97.10	6.08	(2) .50	2.50	1.88	

NOTE: We reserve the right to make reasonable design changes without notice. Consult factory. All dimensions are inches.

Dimensions

Four Pass

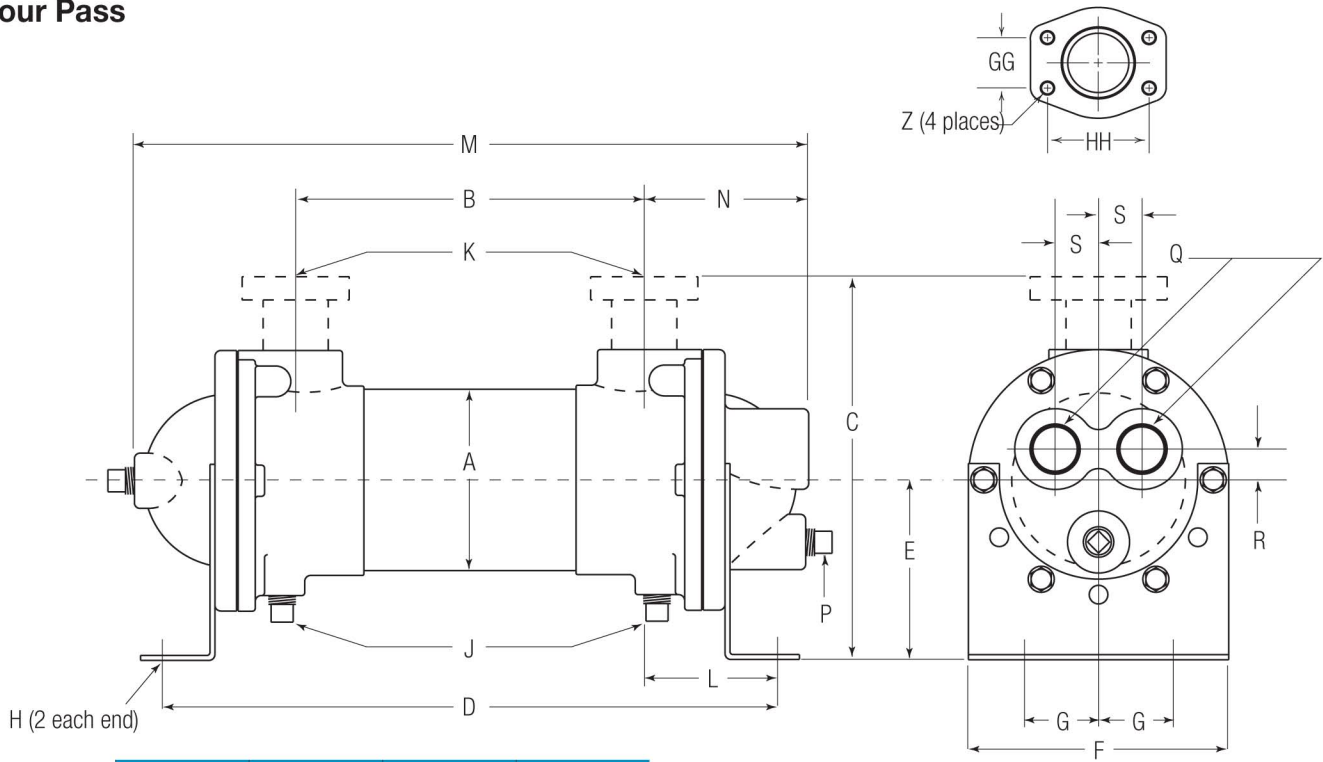

Flange Size	GG	HH	Z - CF	Z - CFM
1	1.03	2.06	3/8-16 UNC	M-10
1.50	1.41	2.75	1/2-13 UNC	M-12
2	1.69	3.06	1/2-13 UNC	M-12
3	2.44	4.19	5/8-11 UNC	M-16

Model	A	B	C		D	E	F	G	H	J NPT	K		L	M	N	P NPT	Q NPT	R	S
			NPT/BSPP SAE O-Ring	SAE Flange							NPT/BSPP Flange	SAE O-Ring							
B-701	3.656	7.00	6.25	C/F	12.01	3.62	5.25	1.50	.44 x 1.00	(2) .38	1.00	#16	2.69	13.57	3.32	(3) .38	.75	.62	.88
B-702	3.656	16.00	6.25	C/F	21.01	3.62	5.25	1.50	.44 x 1.00	(2) .38	1.00	1 1/16-12 UNF-2B	2.69	22.57	3.32	(3) .38	.75	.62	.88
B-703	3.656	25.00	6.25	C/F	30.01	3.62	5.25	1.50	.44 x 1.00	(2) .38	1.00		2.69	31.57	3.32	(3) .38	.75	.62	.88
B-1002	5.125	15.50	7.38	8.46	21.71	4.00	6.75	2.00	.44 x 1.00	(6) .38	1.50		#24	3.06	23.57	4.12	(3) .38	1.00	.75
B-1003	5.125	24.50	7.38	8.46	30.71	4.00	6.75	2.00	.44 x 1.00	(6) .38	1.50	1 1/8-12 UN-2B	3.06	32.57	4.12	(3) .38	1.00	.75	1.34
B-1004	5.125	33.50	7.38	8.46	39.71	4.00	6.75	2.00	.44 x 1.00	(6) .38	1.50		3.06	41.57	4.12	(3) .38	1.00	.75	1.34
B-1202	6.125	14.62	8.81	10.50	21.50	4.75	7.50	2.50	.44 x .88	(6) .38	2.00		#32 2 1/2-12 UN-2B	3.44	24.44	4.90	(2) .38	1.50	1.06
B-1203	6.125	23.50	8.81	10.50	30.38	4.75	7.50	2.50	.44 x .88	(6) .38	2.00	3.44		33.31	4.90	(2) .38	1.50	1.06	1.40
B-1204	6.125	32.38	8.81	10.50	39.25	4.75	7.50	2.50	.44 x .88	(6) .38	2.00	3.44		42.19	4.90	(2) .38	1.50	1.06	1.40
B-1205	6.125	41.88	8.81	10.50	48.25	4.75	7.50	2.50	.44 x .88	(6) .38	2.00	3.44		51.19	4.90	(1) .50	1.50	1.06	1.40
B-1206	6.125	50.50	8.81	10.50	57.38	4.75	7.50	2.50	.44 x .88	(6) .38	2.00	3.44		60.31	4.90	(1) .50	1.50	1.06	1.40
B-1207	6.125	59.50	8.81	10.50	66.38	4.75	7.50	2.50	.44 x .88	(6) .38	2.00	3.44		69.31	4.90	(1) .50	1.50	1.06	1.40
B-1208	6.125	38.38	8.81	10.50	75.25	4.75	7.50	2.50	.44 x .88	(6) .38	2.00	3.44		78.19	4.90	(1) .50	1.50	1.06	1.40
B-1602	8.00	13.60	12.13	15.61	22.38	6.50	8.62	3.50	.44 x 1.00	(6) .38	3.00	—		4.39	26.72	6.48	(3) .50	2.00	1.88
B-1603	8.00	22.60	12.13	15.61	31.88	6.50	8.62	3.50	.44 x 1.00	(6) .38	3.00	—	4.39	35.72	6.48	(3) .50	2.00	1.88	1.88
B-1604	8.00	31.60	12.13	15.61	40.38	6.50	8.62	3.50	.44 x 1.00	(6) .38	3.00	—	4.39	44.72	6.48	(3) .50	2.00	1.88	1.88
B-1605	8.00	40.60	12.13	15.61	49.38	6.50	8.62	3.50	.44 x 1.00	(6) .38	3.00	—	4.39	53.72	6.48	(3) .50	2.00	1.88	1.88
B-1606	8.00	49.60	12.13	15.61	58.38	6.50	8.62	3.50	.44 x 1.00	(6) .38	3.00	—	4.39	62.72	6.48	(3) .50	2.00	1.88	1.88
B-1607	8.00	58.60	12.13	15.61	67.38	6.50	8.62	3.50	.44 x 1.00	(6) .38	3.00	—	4.39	71.72	6.48	(3) .50	2.00	1.88	1.88
B-1608	8.00	67.60	12.13	15.61	76.38	6.50	8.62	3.50	.44 x 1.00	(6) .38	3.00	—	4.39	80.72	6.48	(3) .50	2.00	1.88	1.88
B-1609	8.00	76.60	12.13	15.61	85.38	6.50	8.62	3.50	.44 x 1.00	(6) .38	3.00	—	4.39	89.72	6.48	(3) .50	2.00	1.88	1.88
B-1610	8.00	85.60	12.13	15.61	94.38	6.50	8.62	3.50	.44 x 1.00	(6) .38	3.00	—	4.39	98.72	6.48	(3) .50	2.00	1.88	1.88

NOTE: We reserve the right to make reasonable design changes without notice. Consult factory. All dimensions are inches.

Performance Curves

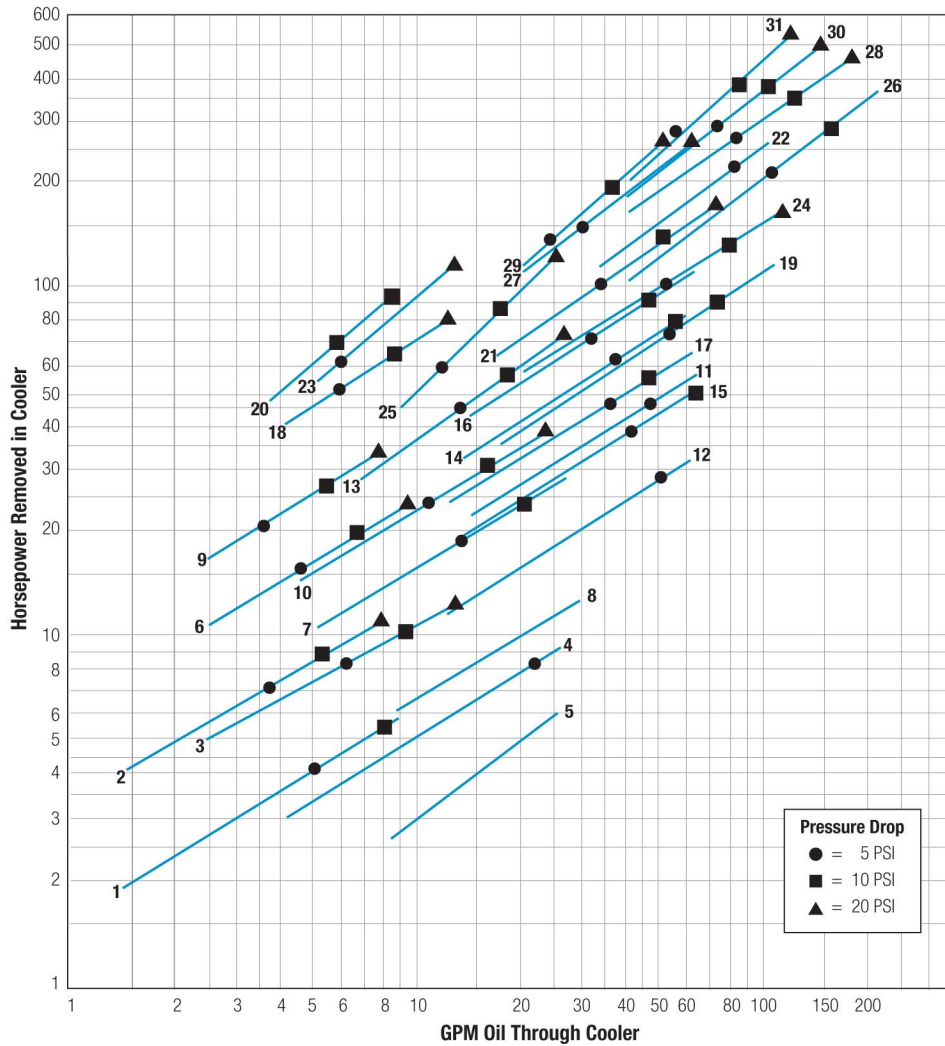

Curve Number	Model	Shipping Weight (LBS)
1	B-401-A4-0	7
2	B-402-A4-0	10
3	B-701-A4-T	23
4	B-701-B6-F	23
5	B-701-C6-T	23
6	B-702-A4-T	28
7	B-702-B4-F	28
8	B-702-C6-T	28
9	B-703-A4-T	35
10	B-703-B4-F	35
11	B-1002-C4-T	49
12	B-1002-C6-T	49
13	B-1003-B4-F	65
14	B-1003-C4-T	65
15	B-1003-C6-T	65
16	B-1004-C4-T	72
17	B-1004-C6-T	72
18	B-1202-A4-F	72
19	B-1202-C4-F	72
20	B-1204-A4-F	110
21	B-1204-C4-F	110
22	B-1206-D4-F	160
23	B-1602-A4-F	145
24	B-1602-C4-F	145
25	B-1604-B4-F	195
26	B-1604-D4-F	195
27	B-1606-C4-F	259
28	B-1606-D4-F	259
29	B-1608-C4-F	310
30	B-1608-D4-F	310
31	B-1610-D4-F	400

Shipping weights are approximate.

Maximum Flow Rates

Example Model No.

B - 1003 - C4 - F

Unit Size	Shell Side (GPM)		Baffle Spacing		Tube Side (GPM)		
	A	B	C	D	O	T	F
400	9.6	—	—	—	25	—	—
700	17	29	29	—	61	31	15
1000	24	48	69	69	146	73	37
1200	29	57	115	115	224	112	56
1600	37	74	149	253	363	181	91

Caution: Incorrect installation can cause this product to fail prematurely, causing the shell side and tube side fluids to intermix.

Piping Diagram

One Pass

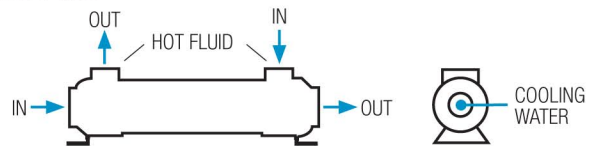

Two and Four Pass

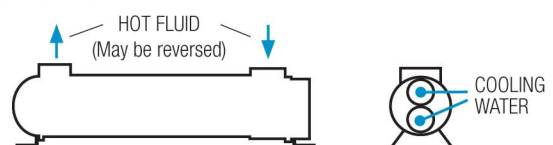

Specific applications may have different piping arrangements. Contact factory for assistance.

Selection Procedure

Performance Curves are based on 100SSU oil leaving the cooler 40°F higher than the water temperature used for cooling. This is also referred to as a 40°F approach temperature. Curves are based on a 2:1 oil to water flow ratio. Curves are 1:1.

STEP 1 Determine the Heat Load. This will vary with different systems, but typically coolers are sized to remove 25 to 50% of the input nameplate horsepower. (Example: 100 HP Power Unit x .33 = 33 HP Heat load.)

$$\text{If BTU/HR is known: } \text{HP} = \frac{\text{BTU/HR}}{2545}$$

STEP 2 Determine Approach Temperature. Desired oil leaving cooler °F – Water Inlet temp. °F = Actual Approach (Max. reservoir temp.)

STEP 3 Determine Curve Horsepower Heat Load. Enter the information from above:

$$\text{Horsepower heat load} \times \frac{40}{\text{Actual Approach}} \times \text{Viscosity} = \frac{\text{Curve Horsepower}}{\text{Correction A}}$$

STEP 4 Enter curves at oil flow through cooler and curve horsepower. Any curve above the intersecting point will work.

STEP 5 Determine Oil Pressure Drop from Curves:
 ● = 5 PSI ■ = 10 PSI ▲ = 20 PSI Multiply pressure drop from curve by correction factor B found on oil viscosity correction curve.

Oil Temperature

Oil coolers can be selected using entering or leaving oil temperatures.

Typical operating temperature ranges are:

Hydraulic Oil	110°F - 130°F
Hydrostatic Drive Oil	130°F - 180°F
Bearing Lube Oil	120°F - 160°F
Lube Oil Circuits	110°F - 130°F

Desired Reservoir Temperature

Return Line Cooling: Desired temperature is the oil temperature leaving the cooler. This will be the same temperature that will be found in the reservoir.

Off-Line Recirculation Cooling Loop: Desired temperature is the oil temperature *entering* the cooler. In this case, the oil temperature change must be determined so that the actual oil leaving temperature can be found. Calculate the oil temperature change (Oil ΔT) with this formula:

$$\text{Oil } \Delta T = (\text{BTUs/HR}) / (\text{GPM Oil Flow} \times 210).$$

To calculate the oil leaving temperature from the cooler, use this formula:

$$\text{Oil Leaving Temp.} = \text{Oil Entering Temp.} - \text{Oil } \Delta T.$$

This formula may also be used in any application where the only temperature available is the entering oil temperature.

Oil Pressure Drop: Most systems can tolerate a pressure drop through the heat exchanger of 20 to 30 PSI. Excessive pressure drop should be avoided. Care should be taken to limit pressure drop to 5 PSI or less for case drain applications where high back pressure may damage the pump shaft seals.

Viscosity Correction

