

# Fluid Cooling Shell & Tube CA-2000 Series

## COPPER & STEEL CONSTRUCTION

### Performance Notes

- Super high flow
- Largest flow rates & heat transfer available
- Rugged steel construction
- Custom designs available
- Competitively priced
- 3/8" and 5/8" tubes available
- Maximum 10" diameter, 12' long
- 150# ANSI/ASME flanged shell connections (metric available)
- End bonnets removable for servicing
- Saddle brackets for incremental mounting
- Special ASME/TEMA C/CRN ratings available



**Options**  
Optional construction on tubes, tubesheets and end bonnets

### Ratings

**Maximum Operating Pressure - Shell Side**  
150 PSI

**Maximum Operating Pressure - Tube Side**  
150 PSI

**Maximum Operating Temperature**  
300°F

### Materials

**Tubes** Copper

**Headers** Steel

**Shell** Steel

**Shell Connections** Steel

**Baffles** Brass

**End Bonnets** Cast Iron

**Mounting Brackets** Steel/cast iron

**Gaskets** Nitrile rubber/cellulose fiber

**Nameplate** Aluminum foil

### Maximum Flow Rates

Shell Side (GPM)		Tube Side (GPM)		
6" Baffle	9" Baffle	One Pass	Two Pass	Four Pass
210	320	652	326	163

### How to Order

<input type="text"/>	-	<input type="text"/>	-	<input type="text"/>	-	<input type="text"/>	-	<input type="text"/>	-	<input type="text"/>	-	<input type="text"/>	-	<input type="text"/>		
<b>Model Series</b>		<b>Model Size Selected</b>		<b>Baffle Spacing</b>		<b>Tube Diameter Code</b>		<b>Tubeside Passes</b>		<b>Cooling Tube Material</b>		<b>End Bonnet Material</b>		<b>Tubesheet Material</b>		<b>Zinc Anodes</b>
CA CAM						6 - 3/8" 10 - 5/8"		O - One Pass T - Two Pass F - Four Pass		Blank - Copper CN - CuNi SS - Stainless Steel AD - Admiralty Brass		Blank - Cast Iron NP - Electroless Nickel Plate		Blank - Cast Iron W - CuNi S - Stainless Steel		Blank - None Z - Zinc

**CA** = ANSI/ASME shell side flanges; NPT tubeside bottom connections (two & four pass); ANSI/ASME flanges on tube side (one pass).

**CAM** = ANSI/ASME shell side metric flanges; BSPP tubeside connections (two & four pass); ANSI/ASME metric flanges on tube side (one pass).

# Dimensions

## One Pass

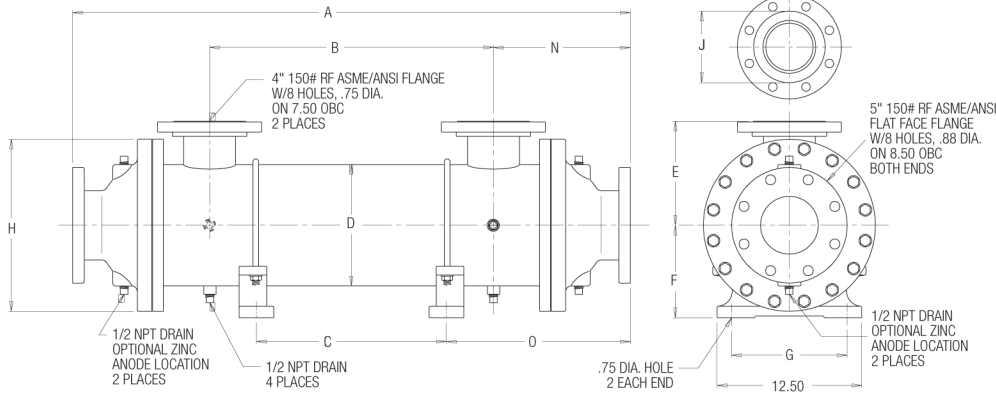

Model	A	N	O
CA-2036	49.64	11.82	15.92
CA-2048	61.64	11.82	15.92
CA-2060	73.64	11.82	15.92
CA-2072	85.64	11.82	15.92
CA-2084	97.64	11.82	15.92
CA-2096	109.64	11.82	15.92
CA-20108	121.64	11.82	15.92
CA-20120	133.64	11.82	15.92
CA-20132	145.64	11.82	15.92
CA-20144	157.64	11.82	15.92

## Two Pass

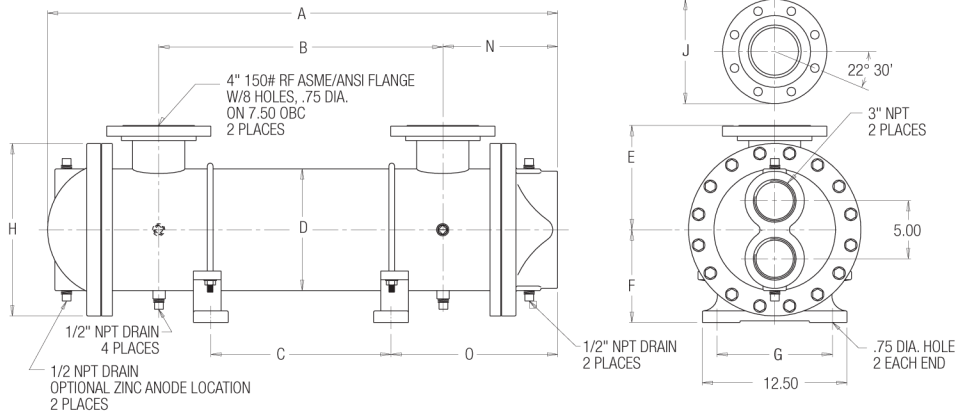

Model	A	N	O
CA-2036	45.55	9.90	14.38
CA-2048	57.55	9.90	14.38
CA-2060	69.55	9.90	14.38
CA-2072	81.55	9.90	14.38
CA-2084	93.55	9.90	14.38
CA-2096	105.55	9.90	14.38
CA-20108	117.55	9.90	14.38
CA-20120	129.55	9.90	14.38
CA-20132	141.55	9.90	14.38
CA-20144	153.55	9.90	14.38

## Four Pass

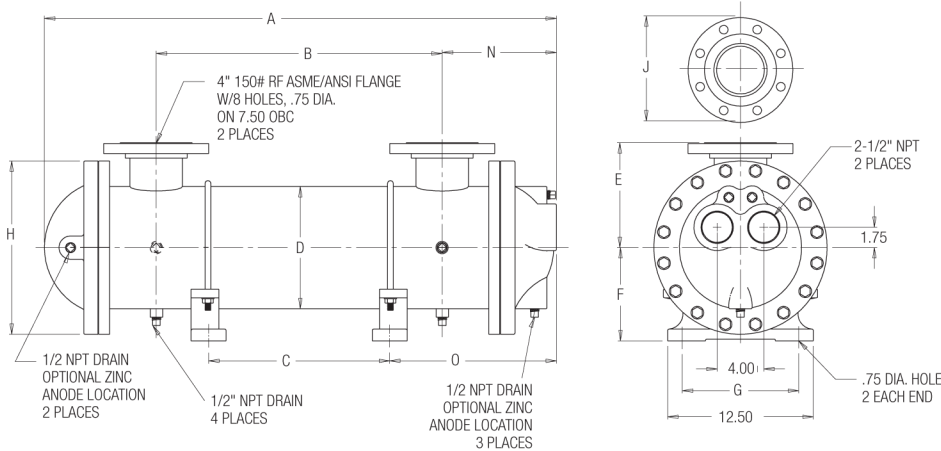

Model	A	N	O
CA-2036	45.34	9.78	13.78
CA-2048	57.34	9.78	13.78
CA-2060	69.34	9.78	13.78
CA-2072	81.34	9.78	13.78
CA-2084	93.34	9.78	13.78
CA-2096	105.34	9.78	13.78
CA-20108	117.34	9.78	13.78
CA-20120	129.34	9.78	13.78
CA-20132	141.34	9.78	13.78
CA-20144	153.34	9.78	13.78

Model	B	C	D Diameter	E	F	G	H Diameter	J
CA-2036	26	18	10.5	9	8	10	14.88	6.19 Diameter Raised Face 2 Places
CA-2048	38	30	10.5	9	8	10	14.88	
CA-2060	50	42	10.5	9	8	10	14.88	
CA-2072	62	54	10.5	9	8	10	14.88	
CA-2084	74	66	10.5	9	8	10	14.88	
CA-2096	86	78	10.5	9	8	10	14.88	
CA-20108	98	90	10.5	9	8	10	14.88	
CA-20120	110	102	10.5	9	8	10	14.88	
CA-20132	122	114	10.5	9	8	10	14.88	
CA-20144	134	126	10.5	9	8	10	14.88	

NOTE: We reserve the right to make reasonable design changes without notice. Dimensions are in inches.

# Performance Curves

## 3/8" Tubes

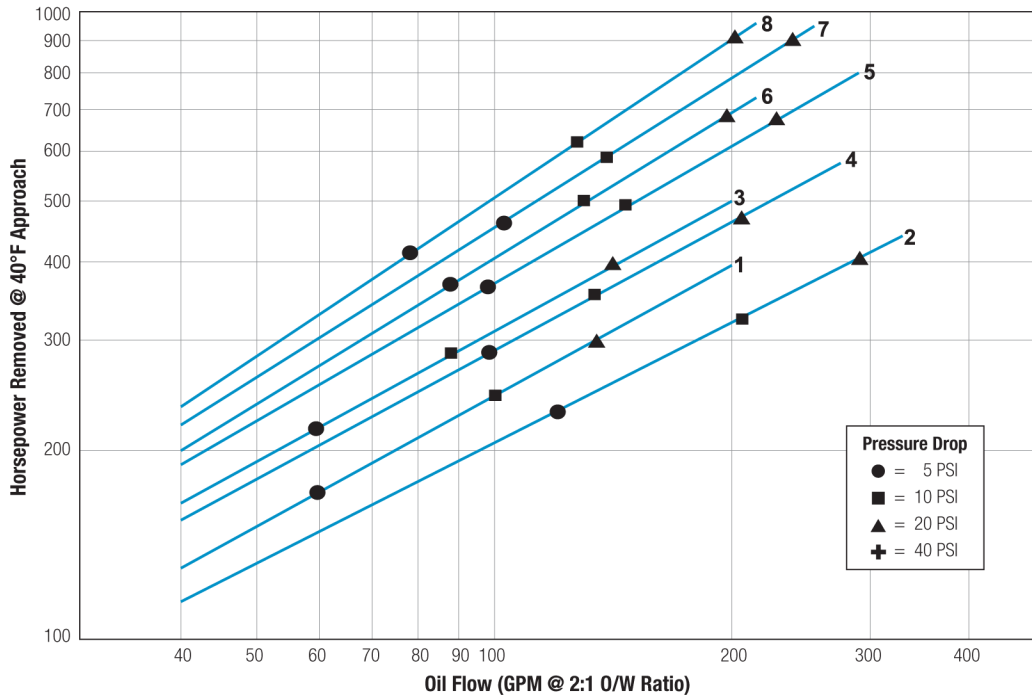

Curve Number	Model
1	CA-2036-6-6-F
2	CA-2036-9-6-F
3	CA-2048-6-6-F
4	CA-2048-9-6-F
5	CA-2072-9-6-F
6	CA-2084-9-6-F
7	CA-20108-9-6-F
8	CA-20132-9-6-F

## 5/8" Tubes

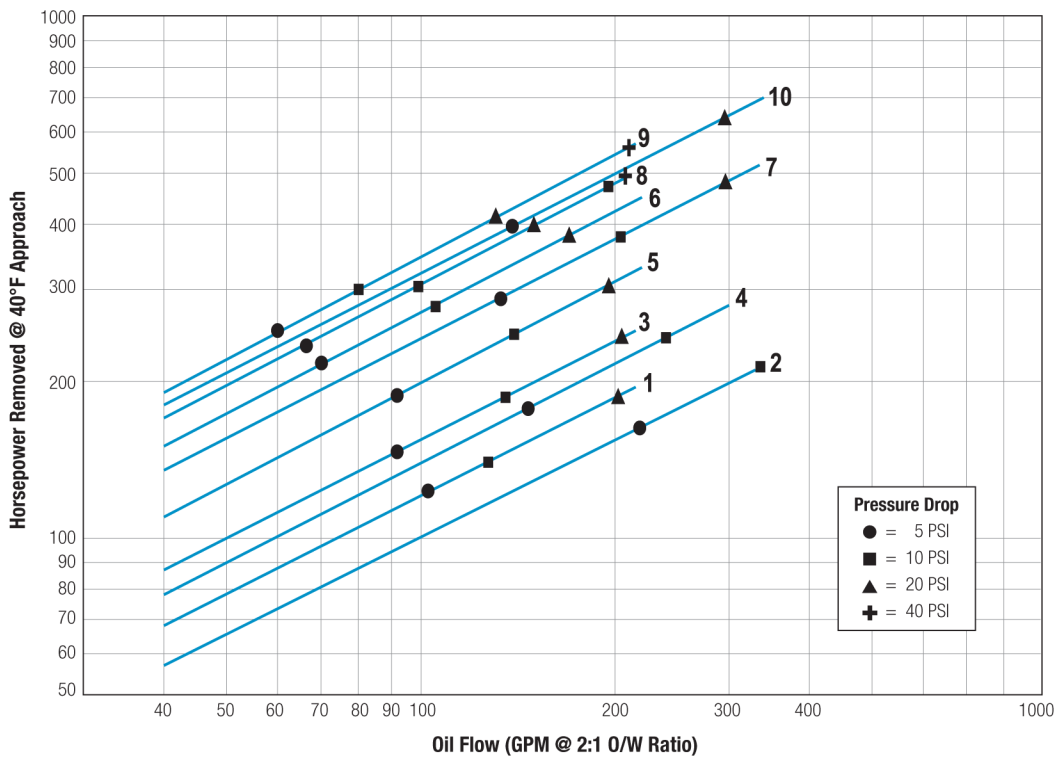

Curve Number	Model
1	CA-2036-6-10-F
2	CA-2036-9-10-F
3	CA-2048-6-10-F
4	CA-2048-9-10-F
5	CA-2060-6-10-F
6	CA-2084-6-10-F
7	CA-2084-9-10-F
8	CA-2096-6-10-F
9	CA-20120-6-10-F
10	CA-20132-9-10-F

# Selection Procedure

Performance Curves are based on 100SSU oil leaving the cooler 40°F higher than the incoming water temperature (40°F approach temperature). Curves are based on a 2:1 oil to water ratio.

**STEP 1 Determine the Heat Load.** This will vary with different systems, but typically coolers are sized to remove 25 to 50% of the input nameplate horsepower. (Example: 100 HP Power Unit x .33 = 33 HP Heat load.)  
If BTU/HR is known:  $HP = \frac{BTU/HR}{2545}$

**STEP 2 Determine Approach Temperature.**  
Desired oil leaving cooler °F – Water Inlet temp. °F =  $\frac{\text{Actual}}{\text{Approach}}$

**STEP 3 Determine Curve Horsepower Heat Load.** Enter the information from above:  
 $HP \text{ heat load} \times \frac{40}{\text{Actual Approach}} \times \frac{\text{Viscosity}}{\text{Correction A}} = \text{Curve Horsepower}$

**STEP 4 Enter curves** at oil flow through cooler and curve horsepower. Any curve above the intersecting point will work.

**STEP 5 Determine Oil Pressure Drop from Curves.** Multiply pressure drop from curve by correction factor B found on oil viscosity correction curve.  
● = 5 PSI   ■ = 10 PSI   ▲ = 20 PSI   + = 40 PSI

## Viscosity Correction

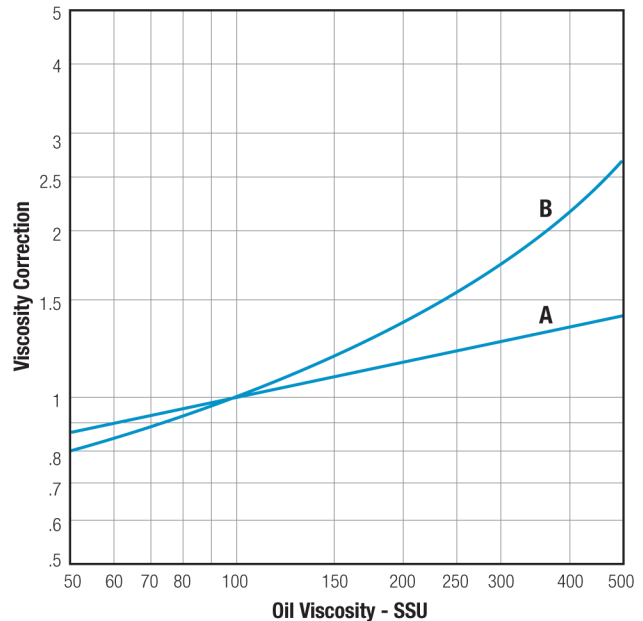

## Oil Temperature

Oil coolers can be selected by using entering or leaving oil temperatures.

Typical operating temperature ranges are:

Hydraulic Motor Oil	110°F - 130°F
Hydrostatic Drive Oil	130°F - 180°F
Lube Oil Circuits	110°F - 130°F
Automatic Transmission Fluid	200°F - 300°F

## Desired Reservoir Temperature

**Return Line Cooling:** Desired temperature is the oil temperature leaving the cooler. This will be the same temperature that will be found in the reservoir.

**Off-Line Recirculation Cooling Loop:** Desired temperature is the temperature entering the cooler. In this case, the oil temperature change must be determined so that the actual oil leaving temperature can be found. Calculate the oil temperature change (Oil ΔT) with this formula:

$$\text{Oil } \Delta T = (\text{BTUs/HR}) / (\text{GPM Oil Flow} \times 210)$$

To calculate the oil leaving temperature from the cooler, use this formula:

$$\text{Oil Leaving Temperature} = \text{Oil Entering Temperature} - \text{Oil } \Delta T$$

This formula may also be used in any application where the only temperature available is the entering oil temperature.

**Oil Pressure Drop:** Most systems can tolerate a pressure drop through the heat exchanger of 20 to 30 PSI. Excessive pressure drop should be avoided. Care should be taken to limit pressure drop to 5 PSI or less for case drain applications where high back pressure may damage the pump shaft seals.